

MANŽETA 0003

Primenjuje se za zaptivanje klipova i klipnjača u hidrauličkim cilindrima.

Uslovi primene manžete 0003 dati su u tabeli

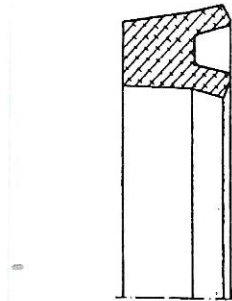

Dozvoljeni pritisak	16 MPa
Temperaturni interval	-30 do +100°C
Radni medijum	Hidrauličko ulje tipa H, HL, HLP emulzija ulje-voda tipa HFA emulzija voda-ulje tip HFB
Dozvoljene brzine	0,5 m/s

Interne oznake materijala za izradu manžete 0003:
70 NBR 14.1, 80 NBR 14.1, 90 NBR 10.1

Veza između veličine zazora klipa i cilindra, odnosno klipnjače i cilindra, pritiska radnog fluida i predviđene tvrdoće materijala data je na dijagramu na slici 5.

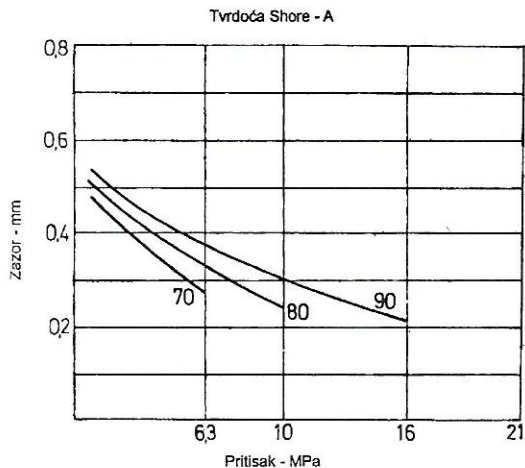

UGRADNO MESTO MANŽETA 0003

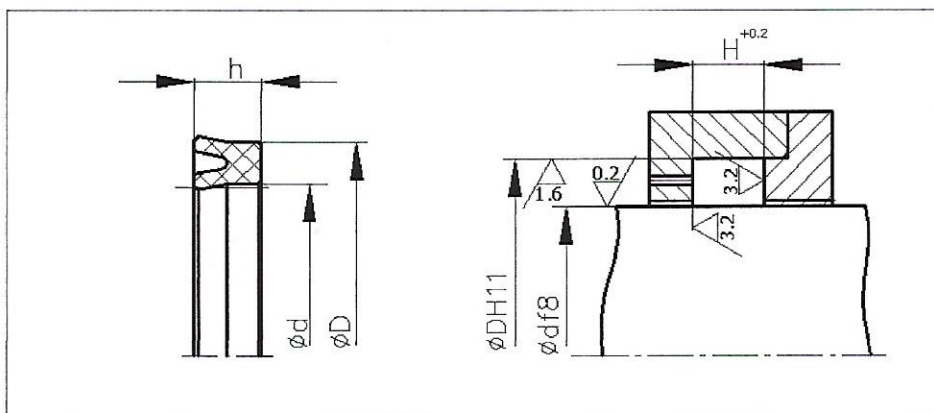

Nazivna veličina	Ød	ØD	h	H
4 X 10	4	10	5	6
4 x 12	4	12	6	7
6 x 12	6	12	6	7
6 x 14	6	14	6	7
8 x 16	8	16	6	7
8 x 18	8	18	8	9
10 x 20	10	20	8	9
10 x 22	10	22	8	9
12 x 22	12	22	8	9
12 x 25	12	25	10	11
14 x 25	14	25	10	14
14 x 28	14	28	10	11
14 x 30	14	30	10	11
16 x 28	16	28	10	11
16 x 30	16	30	10	11
16 x 32	16	32	10	11
18 x 28	18	28	8	9
18 x 30	18	30	10	11
18 x 35	18	35	12	13
20 x 30	20	30	8	9
20 x 32	20	32	8	9
20 x 35	20	35	10	11
22 x 32	22	32	10	11
22 x 35	22	35	10	11
22 x 38	22	38	10	11
25 x 35	25	35	10	11
25 x 38	25	38	10	11
25 x 40	25	40	10	11
25 x 42	25	42	10	11

Primer za naručivanje : za klipnjaču Ø 20 : Manžeta 0003 20 x 32 80 NBR 14.1

UGRADNO MESTO MANŽETA 0003

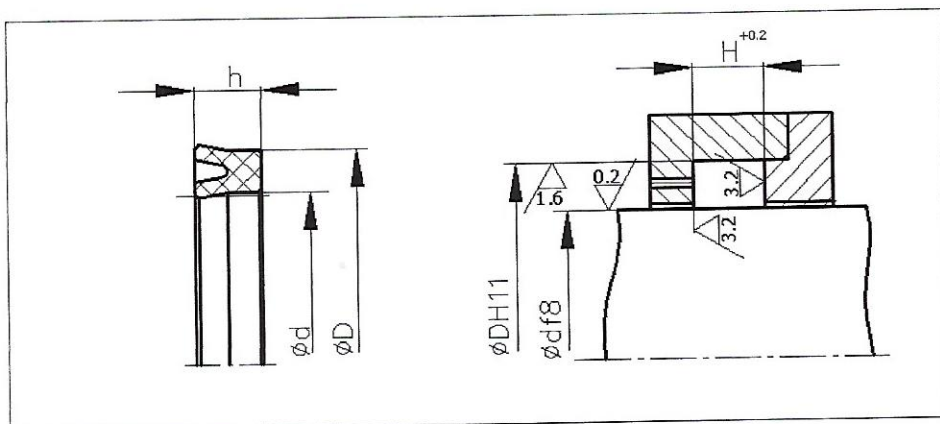

Nazivna veličina	$\varnothing d$	$\varnothing D$	h	H
25 x 45	25	45	10	11
25 x 50	25	50	10	11
28 x 40	28	40	10	11
28 x 42	28	42	10	11
28 x 45	28	45	12	13
28 x 48	28	48	12	13
30 x 40	30	40	10	11
30 x 42	30	42	10	11
30 x 45	30	45	10	11
30 x 48	30	48	10	11
30 x 50	30	50	12	13
32 x 45	32	45	10	11
32 x 48	32	48	10	11
32 x 50	32	50	12	13
32 x 52	32	52	12	13
35 x 48	35	48	10	11
35 x 50	35	50	10	11
35 x 52	35	52	12	13
35 x 55	35	55	12	13
35 x 56	35	56	12	13
38 x 52	38	52	10	11
38 x 55	38	55	12	13
38 x 56	38	56	12	13
38 x 58	38	58	12	13
38 x 60	38	60	12	13
38 x 65	38	65	10	11
40 x 50	40	50	10	11
40 x 55	40	55	10	11
40 x 56	40	53	10	11

Primer za naročivanje : za klipnjaču $\varnothing 40$: Manžeta 0003 40 x 50 80 NBR 14.1

UGRADNO MESTO MANŽETA 0003

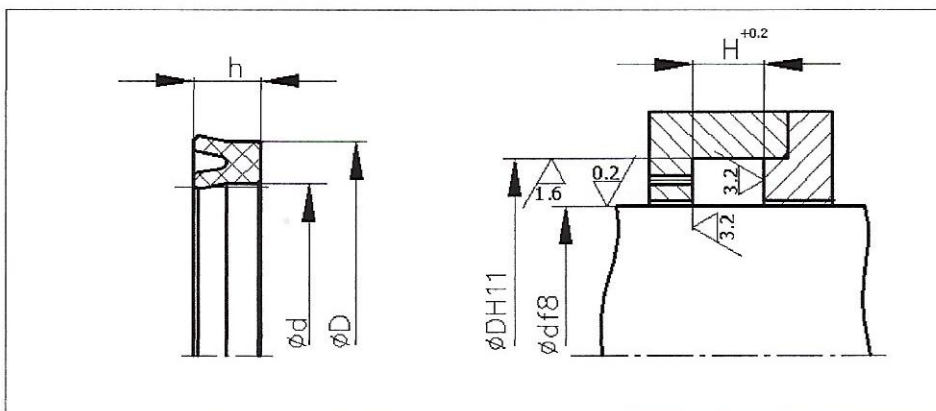

Nazivna veličina	Ød	ØD	h	H
40 x 58	40	58	12	13
40 x 60	40	60	12	13
40 x 62	40	62	12	13
40 x 63	40	63	12	13
42 x 55	42	55	10	11
42 x 56	42	56	10	11
42 x 58	42	58	10	11
42 x 60	42	60	10	11
42 x 62	42	62	12	13
42 x 63	42	63	12	13
45 x 58	45	58	10	11
45 x 60	45	60	10	11
45 x 62	45	62	12	13
45 x 63	45	63	12	13
45 x 65	45	65	12	13
45 x 68	45	68	12	13
48 x 60	48	60	10	11
48 x 62	48	62	12	13
48 x 63	48	63	12	13
48 x 65	48	65	12	13
50 x 65	50	65	10	11
50 x 70	50	70	12	13
50 x 72	50	72	12	13
50 x 75	50	75	12	13
52 x 68	52	68	12	13
52 x 70	52	70	12	13
52 x 72	52	72	12	13
55 x 70	55	70	12	13
55 x 75	55	75	12	13

Primer za naručivanje : zaklipnjaču Ø 50 : Manžeta 0003 50 x 70 80 NBR 14.1

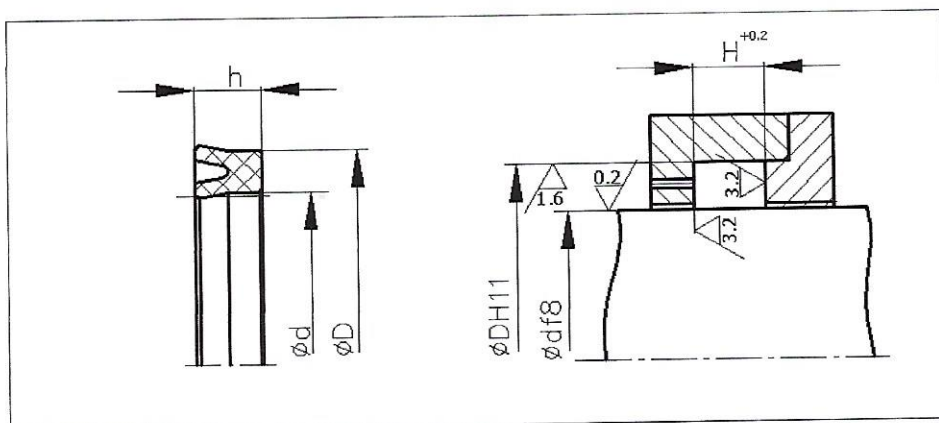

Nazivna veličina	Ød	ØD	h	H
55 x 80	55	80	15	16
56 x 70	56	70	12	13
58 x 75	58	75	12	13
58 x 78	58	78	12	13
60 x 70	60	70	12	13
60 x 75	60	75	12	13
60 x 80	60	80	12	13
60 x 85	60	85	15	16
63 x 78	63	78	12	13
63 x 80	63	80	12	13
63 x 85	63	85	12	13
65 x 80	65	80	12	13
65 x 85	65	85	12	13
65 x 90	65	90	15	16
70 x 85	70	85	12	13
70 x 90	70	90	12	13
70 x 95	70	95	12	13
75 x 90	75	90	12	13
75 x 95	75	95	12	13
75 x 100	75	100	15	16
80 x 95	80	95	12	13
80 x 100	80	100	12	13
80 x 105	80	105	15	16
80 x 110	80	110	15	16
85 x 100	85	100	12	13
85 x 105	85	105	12	13
85 x 110	85	110	15	16
85 x 115	85	115	18	19
90 x 105	90	105	12	13

UGRADNO MESTO MANŽETA 0003

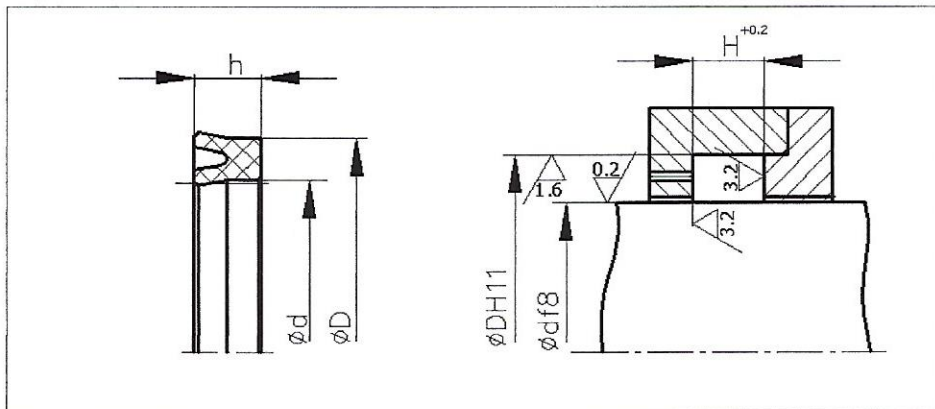

Nazivna veličina	$\varnothing d$	$\varnothing D$	h	H
90 x 110	90	110	15	16
90 x 115	90	115	15	16
90 x 120	90	120	18	19
95 x 110	95	110	12	13
95 x 115	95	115	15	16
95 x 120	95	120	15	16
95 x 125	95	125	18	19
100 x 115	100	115	12	13
100 x 120	100	120	15	16
100 x 125	100	125	15	16
100 x 130	100	130	18	19
105 x 120	105	120	15	16
105 x 125	105	125	15	16
105 x 130	105	130	18	19
105 x 135	105	135	18	19
110 x 125	110	125	15	16
110 x 130	110	130	15	16
110 x 135	110	135	18	19
110 x 140	110	140	18	19
115 x 130	115	130	15	16
115 x 135	115	135	15	16
115 x 140	115	140	18	19
115 x 145	115	145	18	19
120 x 135	120	135	15	16
120 x 140	120	140	15	16
120 x 145	120	145	18	19
120 x 150	120	150	18	19
125 x 140	125	140	15	16
125 x 145	125	145	15	16

Primer za naročanje : za klipnjaču $\varnothing 100$: Manžeta 0003 100 x 125 80 NBR 14.1

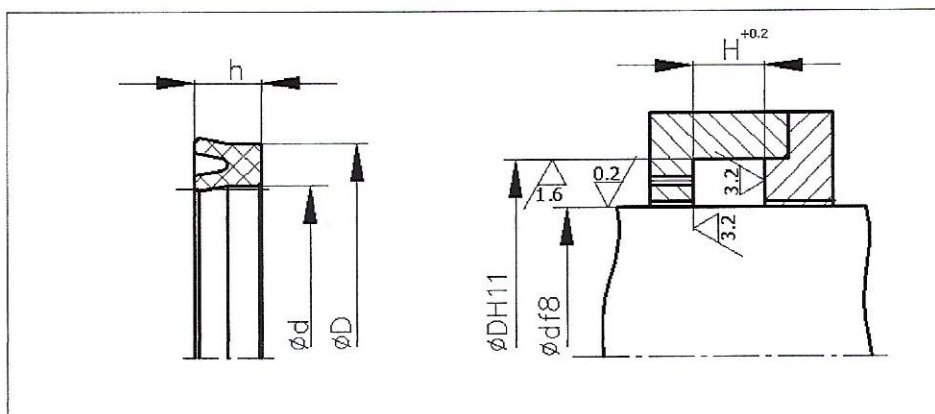
UGRADNO MESTO MANŽETA 0003

Nazivna veličina	$\varnothing d$	$\varnothing D$	h	H
125 x 150	125	150	18	19
125 x 155	125	155	18	19
130 x 145	130	145	15	16
130 x 150	130	150	15	16
130 x 155	130	155	18	19
130 x 160	130	160	18	19
135 x 150	135	150	15	16
135 x 155	135	155	15	16
135 x 160	135	160	18	19
135 x 165	135	165	18	19
140 x 160	140	160	15	16
140 x 165	140	165	18	19
140 x 170	140	170	18	19
145 x 165	145	165	15	16
145 x 170	145	170	18	19
145 x 175	145	175	18	19
150 x 170	150	170	15	16
150 x 180	150	180	18	19
160 x 180	160	180	15	16
160 x 190	160	190	22	23
170 x 190	170	190	15	16
170 x 200	170	200	22	23
180 x 200	180	200	15	16
180 x 210	180	210	22	23
190 x 210	190	210	15	16
190 x 220	190	220	22	23
200 x 220	200	220	15	16
200 x 230	200	230	22	23
220 x 250	220	250	18	19

Primer za naročanje : za klipnjaču $\varnothing 130$: Manžeta 0003 130 x 150 80 NBR 14.1

UGRADNO MESTO MANŽETA 0003

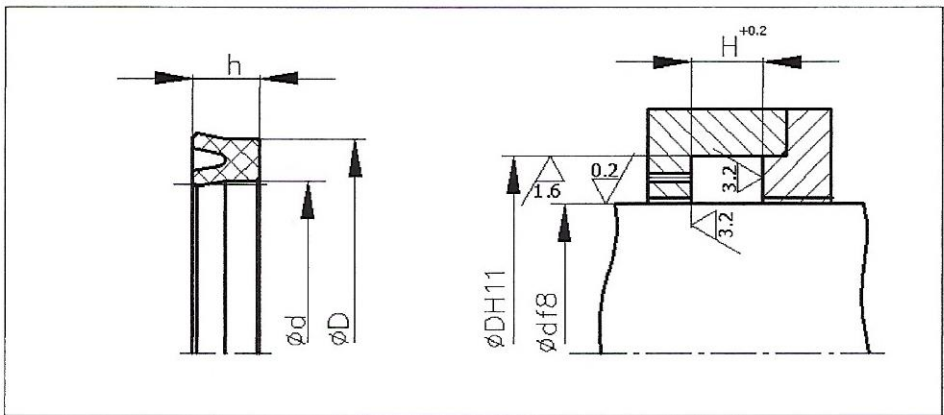

Nazivna veličina	Ød	ØD	h	H
250 x 280	250	280	18	19
270 x 300	270	300	18	19
280 x 310	280	310	18	19
290 x 320	290	320	22	23
300 x 330	300	330	22	23
320 x 350	320	350	22	23
350 x 380	350	380	22	23
370 x 400	370	400	22	23
380 x 410	380	410	22	23
390 x 420	390	420	22	23
400 x 430	400	430	22	23
420 x 420	420	450	22	23

Primer za naručevanje : za klipnjaču Ø 300 : Manžeta 0003 300 x 330 80 NBR 14.1

